

Reference Purpose Translation

Report on Improvements of Post-Trade Processing of  
OTC Derivatives Trades in Japan

by

The Study Group on Post-Trade Processing of  
OTC Derivatives Trades

March 27<sup>th</sup>, 2009

DISCLAIMER: This English version is not an official translation of the original Japanese document. This translation may be used only for reference purposes. Certain parts of the translation may have been edited to accommodate differences in writing style and expression between English and Japanese. In cases where any differences occur between the English version and the original Japanese version, the Japanese version shall prevail. Tokyo Stock Exchange Group, Inc., Tokyo Stock Exchange, Inc. and/or Tokyo Stock Exchange Regulation, Japan Securities Clearing Corporation and/or Japan Securities Depository Center, Inc. shall individually or jointly accept no responsibility or liability for damage or loss caused by any error, inaccuracy, or misunderstanding with regard to this translation.

**Member Companies**  
**of**  
**The Study Group on Post-Trade Processing of OTC Derivatives Trades**

Goldman Sachs Japan Co., Ltd.  
JPMorgan Securities Japan Co., Ltd.  
Daiwa Securities SMBC Co. Ltd.  
Chuo Mitsui Asset Trust and Banking Co.,Ltd.  
Deutsche Securities Inc.  
Nikko Citigroup Limited  
Nomura Securities Co., Ltd.  
Mizuho Corporate Bank, Ltd.  
Mizuho Securities Co., Ltd.  
Sumitomo Mitsui Banking Corporation  
The Bank of Tokyo-Mitsubishi UFJ, Ltd.  
Merrill Lynch Japan Securities Co., Ltd.  
Morgan Stanley Japan Securities Co., Ltd.  
UBS AG, Tokyo Branch

(Observers)

ISDA  
Nishimura & Asahi  
Bank of Japan  
Japan Securities Dealers Association  
Markit Group Japan K.K.  
Mizuho Bank, Ltd. (Chair-bank of the Japanese Bankers Association)  
(In order of Japanese reading)

<Discussion Schedule>

1st Session      Thursday, October 2<sup>nd</sup>, 2008

2nd Session      Wednesday, November 5<sup>th</sup>, 2008

3rd Session      Monday, November 10<sup>th</sup>, 2008

(Exchange of Opinions with DTCC: Wednesday, December 3<sup>rd</sup>, 2008)

4th Session      Friday, December 19<sup>th</sup>, 2008

5th Session      Monday, January 26<sup>th</sup>, 2009

6th Session      Wednesday, February 25<sup>th</sup>, 2009

7th Session      Friday, March 27<sup>th</sup>, 2009

## **I. Introduction**

In recent years, the scale of interest-rate swap trading, credit default swap (CDS) trading, etc. on the over-the-counter (OTC) derivatives market has continued to expand globally. On the other hand, in response to the sub-prime crisis and bankruptcy of major financial institutions overseas, needs for the improvement of the security, transparency, and efficiency of OTC derivatives trading are increasing more than ever. Already in the U.S. and Europe, existing exchanges and clearing houses attempt to undertake post-trade processing of OTC derivatives trading.

Based on this situation, the three companies which make up the infrastructure of financial instruments trade clearing and settlement, Japan Securities Clearing Corporation (JSCC), Japan Securities Depository Center, Inc., and Tokyo Stock Exchange, Inc., jointly established the “Study Group on Post-Trade Processing of OTC Derivatives Trades” on September 9<sup>th</sup>, 2008. The purpose of the group is to improve the security, transparency, and efficiency of OTC derivatives trading in the Japanese markets, thereby contributing to the sound development of OTC derivatives market. The study group held discussions seven times over the past six months.

This is to report those discussions and the result thereof.

## **II. OTC Derivatives Trading and Post-Trade Processing Trends**

There has been remarkable expansion in the market size of OTC derivatives trading in recent years. The global balance of notional principal reached 458

trillion US dollars for interest-rate related trading, and 57 trillion US dollars for CDS trading as of June 2008<sup>1</sup>. This shows, compared to the end of December 2004, approximately 2.4 times growth for interest-rate related trading and about 9.5 times growth for CDS trading. In Japan, as of December 2008, the domestic balance of notional principal reached 24.5 trillion US dollars (about 2,230 trillion Japanese yen) for interest-rate related trading, and 355 billion US dollars (32 trillion Japanese yen) for CDS trading<sup>2</sup>. This represents, compared to the end of December 2004, about 1.7 times growth for interest-rate related trading and approximately 7.9 times growth for CDS trading respectively.

In the midst of this expansion, many parts of post-trade processing for OTC derivatives have been conducted by a manual basis, resulting in problems like the occurrence of backlogs (unprocessed items), losses due to operational errors, and increased handling costs. On the other hand, with the International Swaps and Derivatives Association (ISDA) taking a central position, advances have been made with standardized documents such as the Master Confirmation Agreement for OTC Derivatives Trading. With these initiatives, progress has also been made regarding the standardization of post-trade processing and the offering of electronic platforms through which concerned parties can confirm contract terms. In particular, MarkitWire for interest-rate related trading, and DTCC Deriv/SERV provided by a subsidiary of DTCC (Depository Trust and Clearing Corporation) for CDS, are widely used throughout the industry. Also, the Trade Information Warehouse (TIW), a trade information gathering database service provided by the aforementioned DTCC, is establishing a user base

---

<sup>1</sup> BIS statistics.

<sup>2</sup> Bank of Japan's "Regular Derivatives Market Statistics in Japan"

among trading participants globally.

Furthermore, in terms of CCP functions, “SwapClear”, operated by LCH.Clearnet, is already firmly established as a supplier of clearing services for interest-rate swap trading overseas. On the CDS front, six organizations worldwide have announced making steps toward providing clearing services. Of those groups, NYSE Liffe, a derivatives exchange affiliated with the transatlantic exchange group NYSE Euronext, has expanded Bclear which offers equity derivatives clearing service, by launching clearing services targeted to three European CDS indexes, such as iTraxx Europe, in December 2008. Also, ICE Trust, a subsidiary of the IntercontinentalExchange(ICE) began operating a clearing service for the American CDS index in March, 2009.

### **III. Discussions in the Study Group**

Within the broad spectrum of OTC derivatives trading, the study group focused on the subject of interest-rate swap trading and CDS trading, given their large volume of transactions among Japanese financial institutions. In order to obtain a solid understanding of the current state of post-trade processing, results of surveys and interviews of member companies were compiled. The study group also had a meeting to exchange opinions with the DTCC, which provides the confirmation infrastructure of CDS trading. Following such, the study group has examined what measures could be considered for implementation in Japan.

#### **1. Summary of the Current State of Post-Trade Processing**

Among various post-trade processing of interest-rate swap trading and CDS

trading, regarding the confirmation processes at member companies, it has become clear that the confirmation of so-called “plain vanilla” products, which make up the majority of interest-rate swap trading, are increasingly dealt with confirmation facilities, such as MarkitWire. It was also found that, the trade confirmation of CDS products, such as index products and single-name products which are eligible for the aforementioned Deriv/SERV and TIW are also progressing toward system-oriented confirmation. This trend is mainly seen in foreign financial institutions, though domestic institutions are also considering introduction of such methods.

With respect to the clearing and settlement of confirmed interest-rate swap trading, the study group has clarified that there was room for improvement regarding the counter-party risk management, the management of collateral, and the transfer of funds in connection with interest payments. Additionally, taking from actual cases of foreign clearing houses, an advantage brought about by processing of positions of a bankrupt clearing participant by a clearing house was acknowledged. Based on these conditions, the study group acknowledged that the introduction of CCP functions should be considered from the viewpoint of the enhancement of creditworthiness in the market through a central counterparty clearing<sup>3</sup>, reducing operational burden through standardization, improving cash management efficiency and facilitating position processing in times of participant bankruptcy. Furthermore, as overseas clearing institutions have already been clearing interest-rate swap trading, the study group concluded that the introduction of CCP functions for interest-rate swap trading should be examined with consideration of overseas trends.

---

<sup>3</sup> Clearing through CCP also holds the merit of falling outside BIS regulated credit risk asset calculation.

Though it was indicated that the CDS trading volume was limited, the study group also confirmed that the clearing and settlement of CDS trading involves similar issues as those of interest-rate swap trading. In light of the potential expansion of the market scale in the future, for the purpose of ensuring safety, relieving operational burdens by standardization, and improving efficiency in cash management, the study group acknowledged that the introduction of CCP functions should also be considered regarding CDS in regards to counter-party risk management, collateral management, and payment/receipt of premiums. The study group also recognized that the market infrastructure such as a CCP should actively function in the settlement at the time of credit events as to the reference entity (credit event settlement), which is unique to the CDS trading. Furthermore, the opinion was voiced that consideration based on the trends of the foundation of overseas clearing institutions should be given in the course of further study regarding introduction of a CCP for CDS trading.

## **2. Discussion based on the Current Condition of Post-Trade Processing**

The use of existing confirmation infrastructures, MarkitWire and Deriv/Serv and TIW, is growing among major market participants, who are expected to be OTC derivatives clearing participants as discussed below. Based on this circumstance, the study group decided to assume that confirmation processing should be made by way of these existing infrastructures. Meanwhile, expansion of the coverage of electronic confirmation processing by provision of a new confirmation system would be considered in line with an enlargement of the clearing participant base.

For the processing of clearing and settlement after confirmation, improvement in security, transparency and effectiveness of counter-party risk management and collateral management along with enhanced cash management efficiency by netting are expected through the introduction of CCP functions. For this reason, the study group concluded that they should aim for introducing CCP functions for interest-rate swap and CDS trading. Based on the consensus, the study group discussed on what CCP functions would be desirable when they were introduced by a clearing institution in Japan.

At the discussion of the introduction of CCP functions by a clearing institution, the secretariat drew up “Draft Outline of Clearing Operations for OTC Derivatives” for interest-rate swap trading and CDS trading. The draft was updated reflecting multiple discussion sessions and opinions from member companies. During discussion there was a keen awareness of the current post-trade processing conditions of member companies as well as the rules and framework employed by overseas clearing houses. In regard to this, deliberation proceeded with careful attention paid to how the domestic rules and framework could maintain compatibility with those overseas. With the results of these discussions, the study group has compiled the draft outline for the introduction of such a clearing institution for Interest-rate swap trading and CDS trading in the attached “Exhibit 1” and “Exhibit 2.”

Henceforth, based on these draft outlines, there will be concrete discussion held on the introduction of a clearing house in Japan for interest-rate swap

trading and CDS trading. In accordance with the current common practice of using the CCP function of LCH.Clearnet's SwapClear for interest-rate swap trading by foreign financial institutions, the opinion was expressed that cooperation with LCH.Clearnet would be required when a clearing institution in Japan is introduced for the clearing of interest-rate swap trading. In this way, while the exiting SwapClear users are able to spare the burden of changing their procedure, interest-rate swap trades between participants of a clearing house in Japan and existing SwapClear users are processed in clearing houses in harmonized ways. Taking such opinions into account, the study group concluded that discussions for establishing coordinated scheme with the foreign clearing institution should be proceeded while the consideration for introducing a clearing institution in Japan.

#### **IV. Conclusion**

This concludes the summary of discussions held by this study group.

Following April of this year, it is hoped that, based on the content of these discussions, detailed consideration for operational procedures including the establishment of a robust risk management process, IT systems, and business analysis will continue with JSCC at the forefront aiming for the launch of clearing operations of interest-rate swap and CDS trading as early as the first half of the next year. In the course of the consideration closely coordinated exchanges of opinions shall be facilitated so that the detailed implementation plans are consistent with the participants' business operations.

Finally, in addition to active discussion from member companies, the study group received generous support from the participating observers: ISDA, Nishimura & Asahi, the Bank of Japan, the Japan Securities Dealers Association, Markit Group Japan K.K., and Mizuho Bank, Ltd. (Chair-bank of the Japanese Bankers Association). The group would like to express its gratitude and deep appreciation.

**Draft Outline of Clearing Operations for OTC Derivatives (Interest-rate Swap Trading)**

Item	Details	Remarks
<p>1. Trades Eligible for Clearing</p>	<p>- To be eligible for clearing, Interest-rate Swap (IRS) trades have to meet all of the following requirements:</p> <p>1) A trade is executed in accordance with ISDA* Master Agreements. *International Swaps and Derivatives Association, Inc.</p> <p>2) A trade is matched through MarkitWire.</p> <p>3) A trade is conducted between clearing participants of Japan Securities Clearing Corporation (JSCC), and they agree to use JSCC services.</p> <p>4) A trade is denominated in Japanese Yen, US dollars or Euro.</p> <p>5) The notional amount of a trade remains consistent throughout the contracted period and a trade includes the exchange of a fixed interest payment for a floating interest payment.*</p>	<p>- For the image of the operation flow, see Attachment 1-1.</p> <p>- The possible expansion of the range of the products to be cleared will be considered later, based on the needs of users.</p> <p>- Whatever description with regard to MarkitWire in this document is subject to an agreement with Markit.</p> <p>- A Trade under “Brokerage for Clearing of Securities (BCS)” is included*. (*A trade cleared by a third party is stipulated as “BCS” under Financial Instruments and Exchange Act of Japan.)</p>

Item	Details	Remarks
<p>2. Qualifications of Clearing Participants</p> <p>(1) IRS Clearing Qualification</p>	<p>(*As to interest payment, LIBOR or TIBOR for Japanese-yen-denominated trades, LIBOR for US-dollar-denominated trades, and LIBOR or EURIBOR for Euro-denominated trades shall be applied.)</p> <p>6) Maximum residual term is not longer than 10,970 days (30 years).</p> <p>7) The notional amount is not more than JPY 10 trillion.</p> <p>- Outstanding trades, if all the requirements are met, shall be treated as eligible trades for clearing.</p> <p>- Clearing Qualification for IRS (IRS Clearing Qualification) shall be newly established. Participants who have obtained such qualification shall be regarded as clearing participants for IRS (IRS Clearing Participant).</p>	<p>- IRS Clearing Qualification shall be treated as a different qualification from CDS Clearing Qualification or JSCC's current Clearing Qualifications (those for cash products, securities options, JGB futures/options and Index futures/options.)</p> <p>- No Classification by category of Principal/Agency Clearing Qualification shall</p>

Item	Details	Remarks
<p>(2) Requirements for obtaining /maintaining IRS Clearing Qualification</p>	<ul style="list-style-type: none"> <li>- Applicants who meet all of the following requirements can obtain IRS Clearing Qualification followed by due approval by JSCC.</li> <li>1) An applicant company is a financial instruments business operator (a securities company) or a registered financial institution (a bank or a credit union).</li> <li>2) An applicant company maintains sound financial conditions*. (*The minimum requirement for net assets (shareholders' equity) is JPY 500 billion.)</li> <li>3) An applicant company has an appropriate management and business-execution structure.</li> <li>- Requirements to maintain IRS Clearing Qualification shall be similar ones with above-mentioned requirements (for obtaining IRS Clearing</li> </ul>	<p>apply.</p> <ul style="list-style-type: none"> <li>- Criteria for net assets (shareholders' equity) may be exempted if an applicant's parent company with at least JPY 500 billion net asset provides a guarantee.</li> <li>- The possibility of the introduction of the rating criteria will be considered later.</li> <li>- One of the requirements shall be the ability of participants to take part in the procedures for the settlement of a defaulting participant's portfolio. To confirm the ability, requirements regarding the size of portfolio held by participants shall be set.</li> </ul>

Item	Details	Remarks
(3) Obligation of IRS Clearing Participants	<p>Qualification).</p> <ul style="list-style-type: none"> <li>- IRS Clearing Participants shall be required to undertake similar obligations with current clearing participants, such as obligations to make notifications or reports.</li> <li>- In the case of a clearing participant's default, the other clearing participants are required to participate in the procedures for the settlement of a defaulting clearing participant's portfolio, such as a neutralization of the risk of the portfolio, implementation of auction, or take-up of transferred positions when auction contracts are not formed.</li> </ul>	<ul style="list-style-type: none"> <li>- As for the participation in the procedures for the settlement of a defaulting clearing participant's portfolio, the following matters have to be considered. The details will be considered later.</li> <li>- Provision to JSCC of resources needed for the procedures such as advisory for portfolio management to neutralize the portfolio risk, implementation of auction trading concerning a portfolio.</li> <li>- Bid in the auction for portfolios of a defaulting clearing participant.</li> <li>- Take-up of the relevant portfolio at the price set by JSCC when auction is not formed.</li> </ul>
(4) Brokerage for Clearing of Securities	<ul style="list-style-type: none"> <li>- IRSs in the case where money to be paid/received concerning those trades is managed through accounts opened with non-Japanese brokers such as a swap house can be cleared by JSCC, under Brokerage for Clearing of Securities scheme.</li> </ul>	<ul style="list-style-type: none"> <li>- For the image of the operation flow regarding these transactions under Brokerage for Clearing of Securities, see Attachment 1-2.</li> <li>- IRS trading managed through accounts opened</li> </ul>

Item	Details	Remarks
<p>3. Assumption of Obligation</p> <p>(1) Requirements of obligation assumption</p> <p>(2) Point when an obligation is assumed</p>	<ul style="list-style-type: none"> <li>- When all of the following requirements are met, assumption of obligation will be conducted. <ul style="list-style-type: none"> <li>1) Trades meet the above-mentioned requirements for clearing.</li> <li>2) Participants have deposited their margins enough to meet their margin requirements.</li> </ul> </li> <li>- JSCC shall assume obligations when it confirms trades meet the requirements shown in the above (1) based on information transferred from MarkitWire.</li> <li>- Confirmation of the eligibility of a trade and the resulting obligation assumption shall be conducted at a specific interval and until a cut-off time. Confirmation/Assumption after the cut-off time shall be treated as</li> </ul>	<p>with Japanese brokers can be cleared by Brokerage for Clearing of Securities as well.</p> <ul style="list-style-type: none"> <li>- Specific qualifications for clearing-commissioning participants under Brokerage for Clearing of Securities shall not be set.</li> <li>- JSCC will notify clearing participants of the results as to whether a trade is eligible or not and of the details of obligation to be assumed.</li> <li>- Margins have to be deposited before obligations are assumed.</li> <li>- The specific interval or the frequency will be considered later.</li> </ul>

Item	Details	Remarks
4. Margins	<p>having being made at the following date.</p> <ul style="list-style-type: none"> <li>- To manage risks associated with positions owned by clearing participants, those participants shall deposit and/or transfer the following margins:               <ol style="list-style-type: none"> <li>1) Initial Margin: The estimated loss amount resulting from settlement due to the default of a clearing participant will be calculated based on specific scenarios and such amount will be deposited.</li> <li>2) Variation Margin: As a result of daily mark-to-market of positions using the zero coupon yield curve, the amount corresponding to the difference from the market price as of the previous trading day will be transferred.</li> <li>3) Intraday Margin : At some point during a trading day, margins will be re-calculated. In the case of the deficit, such amount shall be deposited by a specific deadline on the same day.</li> </ol> </li> </ul>	<ul style="list-style-type: none"> <li>- JSCC shall calculate the amount of margins and notify clearing participants of such amounts.</li> <li>- Calculation method of margins (calculation model) will be considered later by taking into consideration that JSCC will the same model as LCH Clearnet.</li> <li>- The introduction of a margin system where margin amounts will be determined based on the rating will be considered later, in connection with the inclusion of the rating criteria in requirements for obtaining/maintaining a clearing qualification.</li> <li>- The rate used for mark-to-market evaluation or the timing of the transfer of variation margins will be considered later.</li> <li>- The rate used for calculating intraday margins or the timing of re-calculation or the margin transfer will be considered later.</li> </ul>

Item	Details	Remarks
5. Interest Payment	<ul style="list-style-type: none"> <li>- Securities in lieu of cash can be deposited as initial margins and intraday margins, in addition to cash such as JPY, US dollar, and Euro. Those securities include government bonds and stocks.</li> <li>- The transfer of variation margins for JPY-denominated trading are made in JPY, and that for USD-denominated trading and Euro-denominated trading are made in US dollar and Euro, respectively.</li> <li>- Interest on initial margins and intraday margins deposited in US dollar or Euro shall be paid, but interest on those deposited in JPY shall not be paid.</li> <li>- The possibility of paying interest on variation margins will be considered later, including the consideration of the cut-off time.</li>   <li>- The amounts to be transferred between JSCC and clearing participants shall be the amounts obtained after the netting of interest and variation margins which is to be paid/received on each interest-payment date and by currency.</li> </ul>	<ul style="list-style-type: none"> <li>- Details of the fund transfer regarding initial margins, intraday margins and variation margin, will be considered later, including the matters such as the implementation of fund transfer under the instruction from JSCC, the use of commercial banks or the treatment of foreign currencies.</li> <li>- In the case of a default of commercial banks which handle foreign currency, clearing participants shall be obliged to compensate for losses incurred by JSCC as a result of that default.</li>   <li>- JSCC will calculate the amounts transferred and notify it of clearing participants.</li> <li>- JSCC will notify clearing participants of reset rates.</li> <li>- Details of the fund transfer will be considered later, including the matters such as the implementation of fund transfer under the instruction from the JSCC, the use of commercial banks or the treatment of foreign currencies.</li> </ul>

Item	Details	Remarks
6. Clearing Funds	<ul style="list-style-type: none"> <li>- To be prepared for losses resulting from the default of a clearing participant who has not paid variation margins, clearing funds shall be deposited by each clearing participant. The required amount shall be calculated based on the amounts of variation margins paid in the past.</li> <li>- In addition to cash such as JPY, US dollar, and Euro, securities in lieu of cash can be deposited as clearing funds. Those securities include government bonds and stocks.</li> <li>- Interest on clearing funds deposited in US dollar or Euro shall be paid, while interest on those in JPY shall not be paid.</li> </ul>	<ul style="list-style-type: none"> <li>- In the case of a default of commercial banks which handle foreign currency, clearing participants shall be obliged to compensate for losses as a result of that default incurred by JSCC.</li> <li>- JSCC will calculate the amount of clearing funds and notify it of clearing participants.</li> <li>- Details of the fund transfer will be considered later, including the matters such as the implementation of fund transfer under the instruction from the JSCC, the use of commercial banks or the treatment of foreign currencies.</li> <li>- In the case of a default of commercial banks which handle foreign currency, clearing participants shall be obliged to compensate for losses as a result of that default incurred by JSCC.</li> </ul>

Item	Details	Remarks
7. Framework of Settlement Execution Guarantees	<ul style="list-style-type: none"> <li>- To prevent systemic risk resulting from JSCC's default, losses incurred by JSCC due to a clearing participant's default shall be compensated in the following order: <ul style="list-style-type: none"> <li>Step1: Defaulting participant's deposits (margins and clearing funds)</li> <li>Step2: Loss compensation by third parties</li> <li>Step3: Special Clearing Charge collected from other participants</li> </ul> </li> </ul>	
8. Novation and Early Termination (termination before the termination date )	<ul style="list-style-type: none"> <li>- If a clearing participant intends to implement a novation or early termination, it shall inform JSCC to that effect and get the approval from JSCC.</li> <li>- In the case of early termination, positions shall be settled at market value. Then, the resulting amount will be paid/received as fees for early termination.</li> </ul>	<ul style="list-style-type: none"> <li>- Novation shall only be implemented by an agreement by a transferor, a transferee and the counterparty of the underlying contract. On the other hand, early termination shall require a mutual agreement by both parties of the trade.</li> <li>- Novation shall be implemented on the condition that both a transferor and a transferee deposit required margins, while early termination shall be implemented on the condition that both parties of the trade deposit required margins.</li> </ul>
9. Linkage between	<ul style="list-style-type: none"> <li>- Regarding transactions between clearing participants of JSCC and</li> </ul>	<ul style="list-style-type: none"> <li>- As for the linkage image, see Attachment 1-3.</li> </ul>

Item	Details	Remarks
Clearing Institutions	members of LCH.Clearnet, JSCC is looking to establish a scheme between LCH.Clearnet so that members of LCH.Clearnet can settle trades by the same procedure as usually done. The scheme will include, in addition to the procedures such as the transfer of margins and funds for settlement between JSCC and its clearing members and also between LCH.Clearnet and its members, the transfer of those after the netting between LCH.Clearnet and JSCC to balance the money involved.	- The details of matters such as the transfer of margins and funds for settlement or risk management will be discussed later with LCH.Clearnet.

<END>

DISCLAIMER: This English version is not an official translation of the original Japanese document. This translation may be used only for reference purposes. Certain parts of the translation may have been edited to accommodate differences in writing style and expression between English and Japanese. In cases where any differences occur between the English version and the original Japanese version, the Japanese version shall prevail. Tokyo Stock Exchange Group, Inc., Tokyo Stock Exchange, Inc. and/or Tokyo Stock Exchange Regulation, Japan Securities Clearing Corporation and/or Japan Securities Depository Center, Inc. shall individually or jointly accept no responsibility or liability for damage or loss caused by any error, inaccuracy, or misunderstanding with regard to this translation.

## Interest Rate Swap (IRS) Clearing Diagram

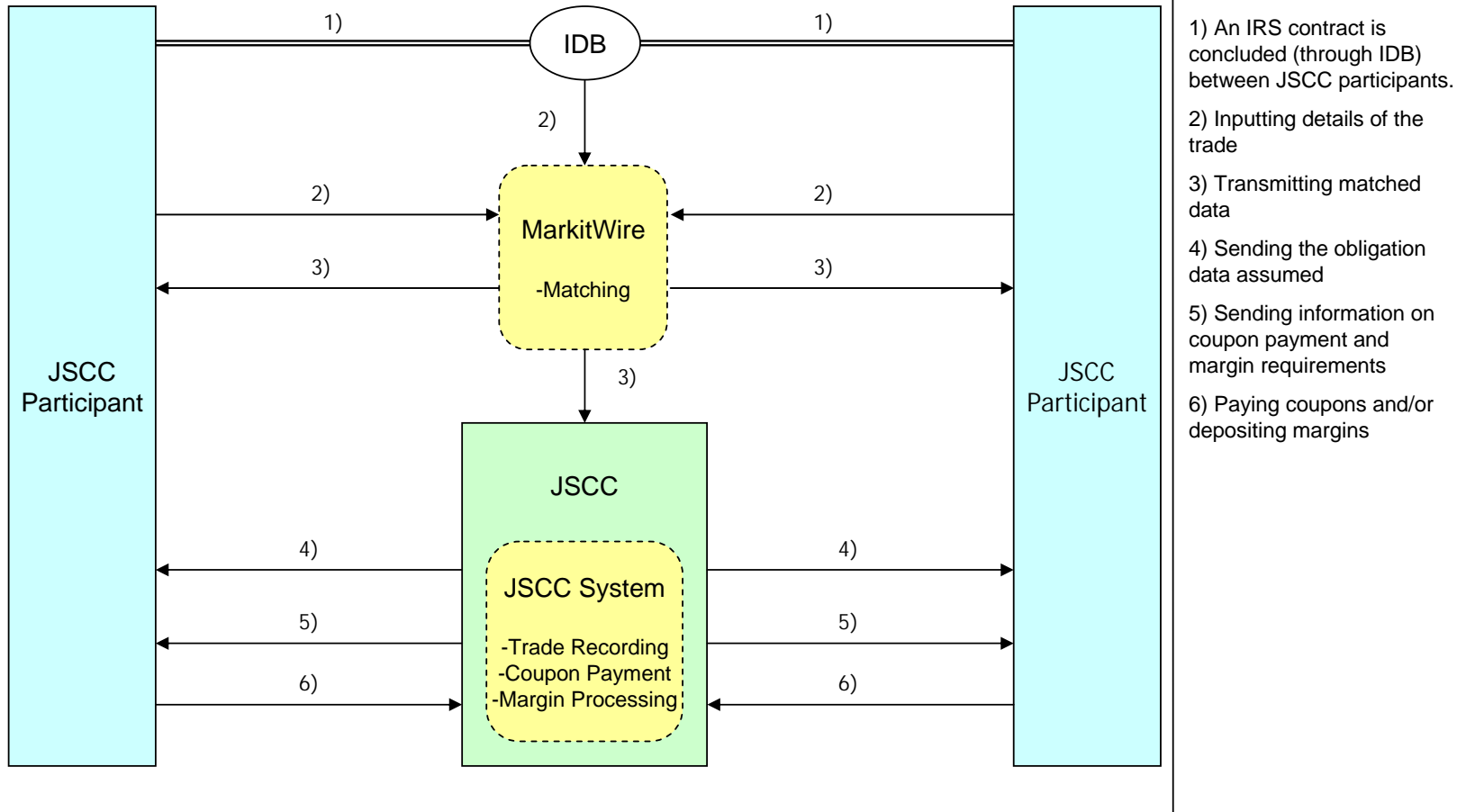

- 1) An IRS contract is concluded (through IDB) between JSCC participants.
- 2) Inputting details of the trade
- 3) Transmitting matched data
- 4) Sending the obligation data assumed
- 5) Sending information on coupon payment and margin requirements
- 6) Paying coupons and/or depositing margins

DISCLAIMER: This English version is not an official translation of the original Japanese document. This translation may be used only for reference purposes. Certain parts of the translation may have been edited to accommodate differences in writing style and expression between English and Japanese. In cases where any differences occur between the English version and the original Japanese version, the Japanese version shall prevail. Tokyo Stock Exchange Group, Inc., Tokyo Stock Exchange, Inc. and/or Tokyo Stock Exchange Regulation, Japan Securities Clearing Corporation and/or Japan Securities Depository Center, Inc. shall individually or jointly accept no responsibility or liability for damage or loss caused by any error, inaccuracy, or misunderstanding with regard to this translation.

## Image for Brokerage for Clearing of Securities regarding IRS

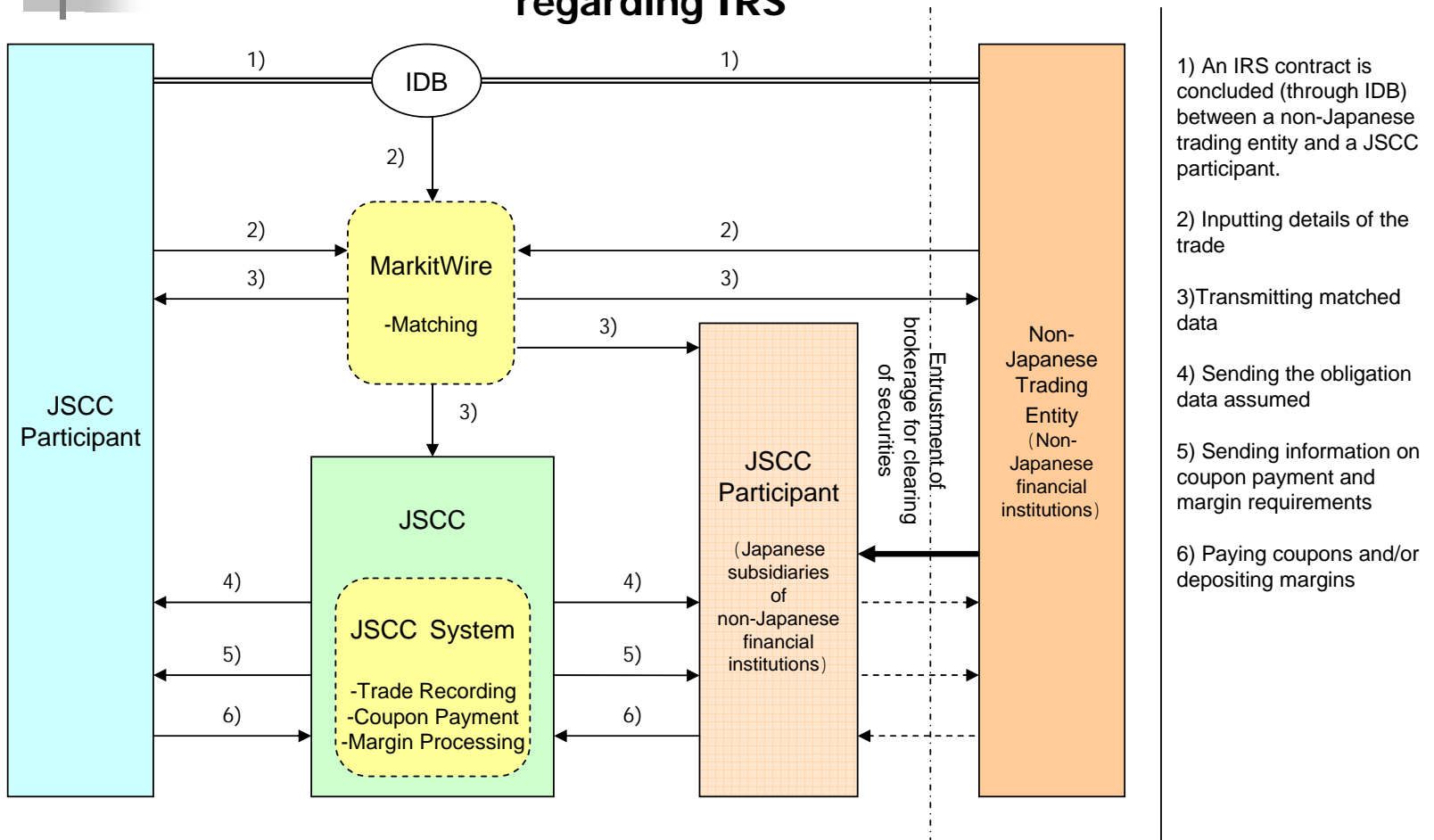

DISCLAIMER: This English version is not an official translation of the original Japanese document. This translation may be used only for reference purposes. Certain parts of the translation may have been edited to accommodate differences in writing style and expression between English and Japanese. In cases where any differences occur between the English version and the original Japanese version, the Japanese version shall prevail. Tokyo Stock Exchange Group, Inc., Tokyo Stock Exchange, Inc. and/or Tokyo Stock Exchange Regulation, Japan Securities Clearing Corporation and/or Japan Securities Depository Center, Inc. shall individually or jointly accept no responsibility or liability for damage or loss caused by any error, inaccuracy, or misunderstanding with regard to this translation.

## Linkage Image between JSCC and a Foreign Clearing House regarding IRS

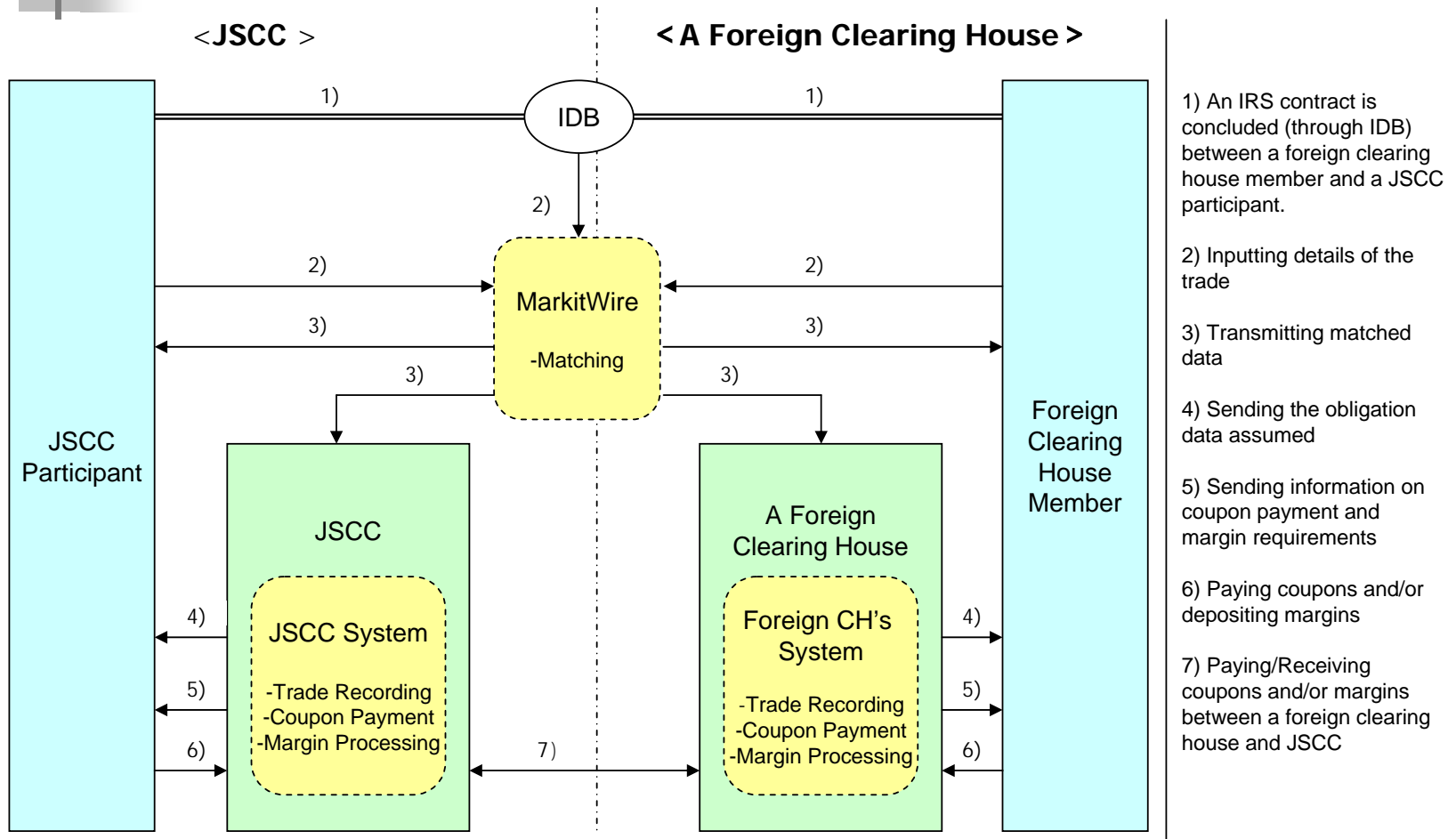

DISCLAIMER: This English version is not an official translation of the original Japanese document. This translation may be used only for reference purposes. Certain parts of the translation may have been edited to accommodate differences in writing style and expression between English and Japanese. In cases where any differences occur between the English version and the original Japanese version, the Japanese version shall prevail. Tokyo Stock Exchange Group, Inc., Tokyo Stock Exchange, Inc. and/or Tokyo Stock Exchange Regulation, Japan Securities Clearing Corporation and/or Japan Securities Depository Center, Inc. shall individually or jointly accept no responsibility or liability for damage or loss caused by any error, inaccuracy, or misunderstanding with regard to this translation.

**Draft Outline of Clearing Operations for OTC Derivatives (Credit Default Swaps Trading)**

Items	Details	Remarks
<p>1. Trades eligible for clearing</p>	<ul style="list-style-type: none"> <li>- To be eligible for clearing, Credit Default Swaps (CDS) trades have to meet all of the following requirements:                             <ol style="list-style-type: none"> <li>1) A trade is executed in accordance with ISDA* Master Agreements. * International Swaps and Derivatives Association, Inc.</li> <li>2) A trade is matched through Deriv/SERV and recorded in Trade Information Warehouse ("TIW") .</li> <li>3) A trade is conducted between clearing participants of Japan Securities Clearing Corporation (JSCC), and they agree to use JSCC services.</li> <li>4) A trade is an Index CDS whose underlying asset is a iTraxx Japan (5 years).</li> </ol> </li> </ul>	<ul style="list-style-type: none"> <li>- For the image of the operation flow, see Attachment 2-1.</li> <li>- The possible expansion of the range of the products to be cleared will be considered later, based on the needs of users.</li> <li>- Whatever description with regard to Deriv/SERV and TIW in this document is subject to an agreement with the Depository Trust &amp; Clearing Corporation (DTCC) is required.</li> <li>- A Trade under "Brokerage for Clearing of Securities (BCS)" is included.* (*A trade cleared by a third party is stipulated as "BCS" under Financial Instruments and Exchange Act of Japan.)</li> <li>- The index shall be the iTraxx Japan main index(5 years) constituted of 50 entities.</li> </ul>

Items	Details	Remarks
2. Qualifications of	<p>5) A trade is denominated in Japanese Yen.</p> <p>6) The definition of credit event is "3CE".</p> <ul style="list-style-type: none"> <li>- Regarding the notional principal amount, maximum and minimum amounts shall be set.</li> <li>- Regarding the contract term, a specific upper limit shall be set.</li> <li>- Outstanding trades, if all the requirements are met, shall be treated as eligible trades for clearing.</li> </ul>	<ul style="list-style-type: none"> <li>- Single name CDSs will launch after the following matters is considered:</li> <li>- Risk management scheme taking into account the relationship between a reference entity and a protection seller.</li> <li>- Handling of single name CDSs based on the fact that initial premium based on the difference between contract spread and fixed spread is not transferred.</li> </ul> <p>- Details will be considered later.</p> <p>- Details will be considered later.</p>



Items	Details	Remarks
(3) Obligation of CDS Clearing Participants	<p>3) An applicant company has an appropriate management and business-execution structure.</p> <ul style="list-style-type: none"> <li>- Requirements to maintain CDS Clearing Qualification shall be similar ones with above-mentioned requirements (for obtaining CDS Clearing Qualification).</li> <li>- CDS Clearing Participants shall be required to undertake similar obligations with current clearing participants, such as obligations to make notifications or reports.</li> <li>- In the case of a clearing participant's default, the other clearing participants are required to participate in the procedures for the settlement of a defaulting clearing participant's portfolio, such as a neutralization of the risk of the portfolio, implementation of auction, or take-up of transferred positions when auction contracts are not formed.</li> </ul>	<ul style="list-style-type: none"> <li>- One of the requirements shall be the ability of participants to take part in the procedures for the settlement of a defaulting participant's portfolio. To confirm the ability, requirements regarding the size of portfolio held by participants shall be set.</li> <li>- As for the participation in the procedures for the settlement of a defaulting clearing participant's portfolio, the following matters have to be considered. The details will be considered later. <ul style="list-style-type: none"> <li>- Provision to JSCC of resources needed for the procedures such as advisory for portfolio management to neutralize the portfolio risk, implementation of auction trading concerning a</li> </ul> </li> </ul>

Items	Details	Remarks
(4) Brokerage for Clearing of Securities	<ul style="list-style-type: none"> <li>- CDSs in the case where money to be paid/received concerning those trades is managed through accounts opened with non-Japanese brokers such as a swap house can be cleared by JSCC, under Brokerage for Clearing of Securities scheme.</li> </ul>	<p>portfolio.</p> <ul style="list-style-type: none"> <li>- Bid in the auction for portfolios of a defaulting clearing participant.</li> <li>- Take-up of the relevant portfolio at the price set by JSCC when auction is not formed.</li> </ul> <ul style="list-style-type: none"> <li>- For the image of the operation flow regarding these transactions under Brokerage for Clearing of Securities, see Attachment 2-2.</li> <li>- CDS trading managed through accounts opened with Japanese brokers can be cleared by Brokerage for Clearing of Securities as well.</li> <li>- Specific qualifications for clearing-commissioning participants under Brokerage for Clearing of Securities shall not be set.</li> </ul>
3. Assumption of obligation (1) Requirements of obligation assumption	<ul style="list-style-type: none"> <li>- When all of the following requirements are met, assumption of obligation will be conducted. <ul style="list-style-type: none"> <li>1) Trades meet the above-mentioned requirements for clearing.</li> <li>2) Participants have deposited their margins enough to meet their</li> </ul> </li> </ul>	<ul style="list-style-type: none"> <li>- JSCC will notify clearing participants of the results as to whether a trade is eligible or not and of the details of obligation to be assumed.</li> <li>- Margins have to be deposited before obligations</li> </ul>

Items	Details	Remarks
<p>(2) Point when an obligation is assumed</p> <p>4. Margins</p>	<p>margin requirements.</p> <ul style="list-style-type: none"> <li>- JSCC shall assume obligations when it confirms trades meet the requirements shown in the above (1) based on information transferred from TIW.</li> <li>- Confirmation of the eligibility of a trade and the resulting obligation assumption shall be conducted at a specific interval and until a cut-off time. Confirmation/Assumption after the cut-off time shall be treated as having being made at the following date.</li> <li>- To manage risks associated with positions owned by clearing participants, those participants shall deposit and/or transfer the following margins: <ul style="list-style-type: none"> <li>1) Initial Margin: The estimated loss amount resulting from settlement due to the default of a clearing participant will be calculated based on specific scenarios and such amount will be deposited.</li> <li>2) Variation Margin: As a result of daily mark-to-market of positions, the</li> </ul> </li> </ul>	<p>are assumed.</p> <ul style="list-style-type: none"> <li>- The specific interval or the frequency will be considered later.</li> <li>- JSCC shall calculate the amount of margins and notify clearing participants of such amounts.</li> <li>- Calculation method of margins (calculation model) will be considered later.</li> <li>- The introduction of a margin system where margin amounts will be determined based on the rating will be considered later, in connection with the inclusion of the rating criteria in requirements for obtaining/maintaining a clearing qualification.</li> <li>- Required amounts shall be calculated based on</li> </ul>

Items	Details	Remarks
<p>5. Fixed-interests payment (transfer of premium)</p>	<p>amount corresponding to the difference from the market price as of the previous trading day will be transferred.</p> <ul style="list-style-type: none"> <li>- Securities in lieu of cash can be deposited as initial margins and variation margins, in addition to cash such as JPY, US dollar, and Euro. Those securities include government bonds and stocks.</li> <li>- Interest on margins deposited in US dollar or Euro shall be paid, but interest on those deposited in JPY shall not be paid.</li> </ul> <p>- The amounts to be transferred between JSCC and clearing participants shall be the amounts obtained after the netting of amounts which is to be paid/received on each fixed-interests payment date.</p>	<p>the total amount of initial margins and variation margins. Transfer of variation margins on a daily basis resulting from the mark-to-marketing shall not be made.</p> <ul style="list-style-type: none"> <li>- The rate used for mark-to-market evaluation or the timing of the transfer of variation margins will be considered later.</li> <li>- Details of the fund transfer regarding margins will be considered later, including the matters such as the implementation of fund transfer under the instruction from JSCC, the use of commercial banks or the treatment of foreign currencies.</li> <li>- In the case of a default of commercial banks which handle foreign currency, clearing participants shall be obliged to compensate for losses incurred by JSCC as a result of that default.</li> </ul> <p>- JSCC will calculate the amounts transferred and notify it of clearing participants through TIW.</p> <ul style="list-style-type: none"> <li>- Details of the fund transfer will be considered later, including the matters such as the</li> </ul>



Items	Details	Remarks
7. Clearing Funds	<ul style="list-style-type: none"> <li>- In the cases where ISDA doesn't conduct auctions, it can be considered that the final price is determined based on the discussion by clearing participants or experts. However, the details will be considered later.</li>   <li>- To be prepared for losses resulting from the default of a clearing participant who has not paid margins, clearing funds shall be deposited by each clearing participant. The required amount shall be calculated based on the increase in margins on a daily basis paid in the past.</li> <li>- In addition to cash such as JPY, US dollar, and Euro, securities in lieu of cash can be deposited as clearing funds. Those securities include government bonds and stocks.</li> <li>- Interest on clearing funds deposited in US dollar or Euro shall be paid, while interest on those in JPY shall not be paid.</li> </ul>	<ul style="list-style-type: none"> <li>agreement with ISDA.</li> <li>- JSCC shall not conduct auctions.</li> <li>- Physical settlement through JSCC will not be made, and only cash settlement based on the final price will be made. Regarding the transactions for which JSCC assumes the obligation, JSCC shall allow clearing participants to participate in the auctions conducted by ISDA. In addition, clearing participants who intend to make physical settlement shall do so by participating in such auction and according to the procedures for such auction.</li>   <li>- JSCC will calculate the amount of clearing funds and notify it of clearing participants.</li>   <li>- Details of the fund transfer will be considered later, including the matters such as the implementation of fund transfer under the instruction from JSCC, the use of commercial banks or the treatment of foreign currencies.</li> <li>- In the case of a default of commercial banks which handle foreign currency, clearing participants shall be obliged to compensate for</li> </ul>

Items	Details	Remarks
8. Framework of settlement execution guarantees	<p>- To prevent systemic risk resulting from JSCC's default, losses incurred by JSCC due to a clearing participant's default shall be compensated in the following order:</p> <p>Step1: Defaulting participant's deposits (margins and clearing funds)</p> <p>Step2: Loss compensation by third parties</p> <p>Step3: Special Clearing Charge collected from other participants</p>	<p>losses as a result of that default incurred by JSCC.</p>
9. Novation and early termination(termination before the termination date )	<p>- If a clearing participant intends to implement a novation or early termination, it shall inform JSCC to that effect through TIW and get the approval from JSCC.</p> <p>- In the case of early termination, positions shall be settled at market value. Then, the resulting amount will be paid/received as fees for early termination.</p>	<p>- Novation shall only be implemented by an agreement by a transferor, a transferee and the counterparty of the underlying contract. On the other hand, early termination shall require a mutual agreement by both parties of the trade.</p> <p>- Novation shall be implemented on the condition that both a transferor and a transferee deposit required margins, while early termination shall be implemented on the condition that both parties of the trade deposit required margins.</p>

Items	Details	Remarks

<END>

DISCLAIMER: This English version is not an official translation of the original Japanese document. This translation may be used only for reference purposes. Certain parts of the translation may have been edited to accommodate differences in writing style and expression between English and Japanese. In cases where any differences occur between the English version and the original Japanese version, the Japanese version shall prevail. Tokyo Stock Exchange Group, Inc., Tokyo Stock Exchange, Inc. and/or Tokyo Stock Exchange Regulation, Japan Securities Clearing Corporation and/or Japan Securities Depository Center, Inc. shall individually or jointly accept no responsibility or liability for damage or loss caused by any error, inaccuracy, or misunderstanding with regard to this translation.

# Credit Default Swap (CDS) Clearing Diagram

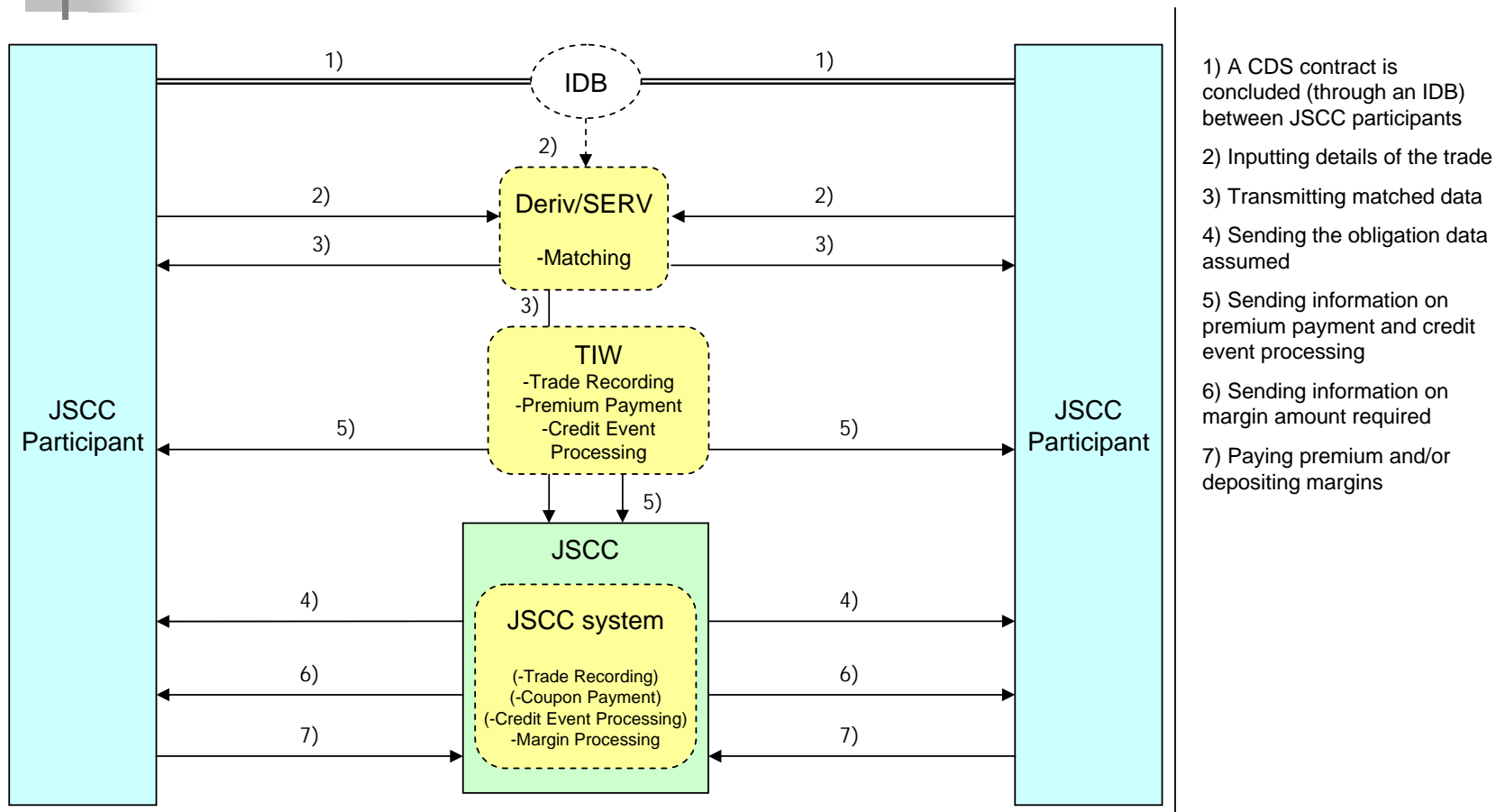

DISCLAIMER: This English version is not an official translation of the original Japanese document. This translation may be used only for reference purposes. Certain parts of the translation may have been edited to accommodate differences in writing style and expression between English and Japanese. In cases where any differences occur between the English version and the original Japanese version, the Japanese version shall prevail. Tokyo Stock Exchange Group, Inc., Tokyo Stock Exchange, Inc. and/or Tokyo Stock Exchange Regulation, Japan Securities Clearing Corporation and/or Japan Securities Depository Center, Inc. shall individually or jointly accept no responsibility or liability for damage or loss caused by any error, inaccuracy, or misunderstanding with regard to this translation.

## Image for Brokerage for Clearing of Securities regarding CDS

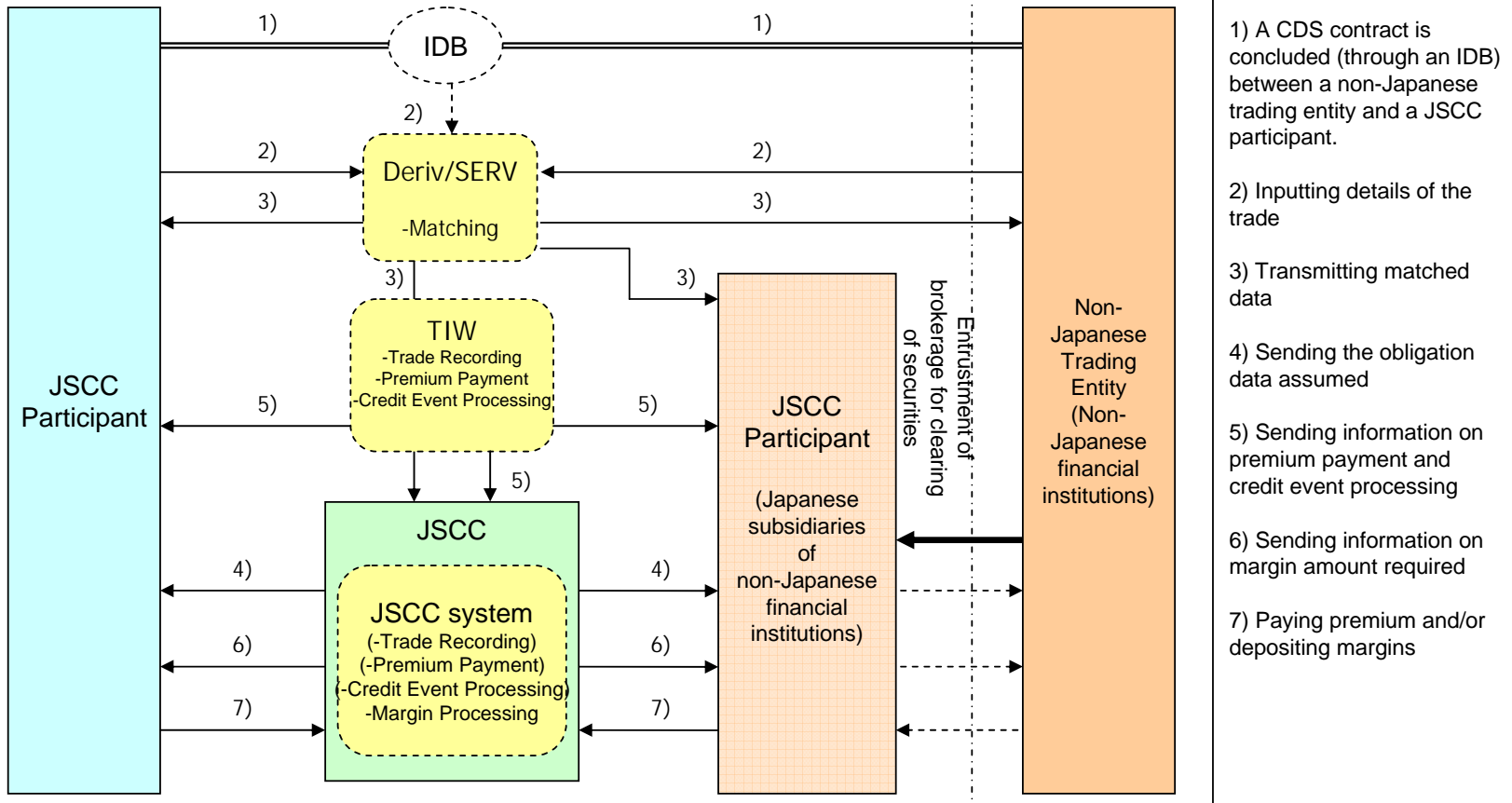

DISCLAIMER: This English version is not an official translation of the original Japanese document. This translation may be used only for reference purposes. Certain parts of the translation may have been edited to accommodate differences in writing style and expression between English and Japanese. In cases where any differences occur between the English version and the original Japanese version, the Japanese version shall prevail. Tokyo Stock Exchange Group, Inc., Tokyo Stock Exchange, Inc. and/or Tokyo Stock Exchange Regulation, Japan Securities Clearing Corporation and/or Japan Securities Depository Center, Inc. shall individually or jointly accept no responsibility or liability for damage or loss caused by any error, inaccuracy, or misunderstanding with regard to this translation.